



P260

- linear steady state characteristics
- integrated hydraulic accumulator
- through shaft
- safe to run dry (liquid)
- self-priming up to 4 meters depth
- liquid fertiliser-proof (AHL/UAN)

Capacity at 5 bar:	260 l/min
Nominal speed:	540 U/min
Operating time pressure:	max. 15 bar
Short-term pressure:	max. 20 bar
Speed range:	450-600 U/min
Spline shaft:	DIN 9611/ISO 500
Standard working diaphragms:	4 x NBR
Accumulator diaphragms:	1 x NBR
Inlet- ϕ suction side:	G2 (BSP) male; d=47
Outlet- ϕ pressure side:	AS30
Lubrication:	Oil bath
Weight:	30 kg
Material:	Cast aluminium, partially anodised, NBR seals, POM, stainless steel: 1.4305

Options:

- Desmopan® diaphragms
- Through shaft
- Hydraulic drive

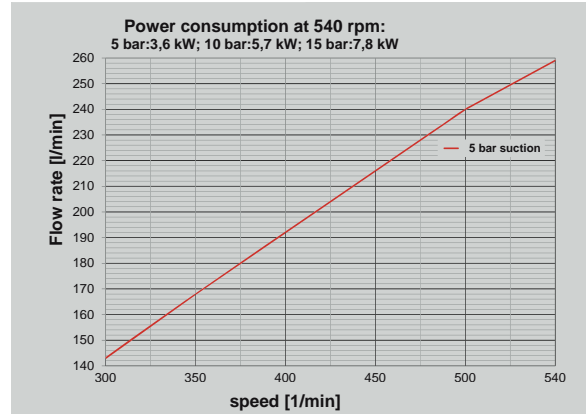

Pump options

Article-No.	Type
82566	Piston diaphragm pump P260
82454	Piston diaphragm pump P260 with hydraulic motor OMR 50 and bracket
More variations on request	
Recommended fittings inlet (AS2)	
--	Fittings to suit G2" male
Recommended fittings outlet (AS1)	
33793	Plug-in hose tail AS30/ ϕ 33/90° cpl
01399	Plug-in hose tail AS30/ ϕ 33 cpl

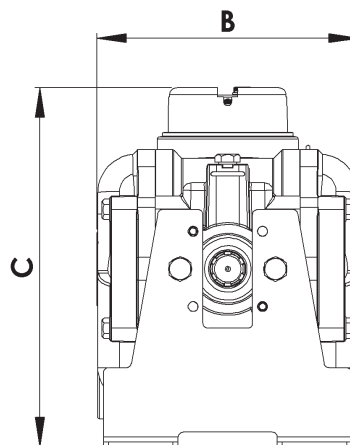
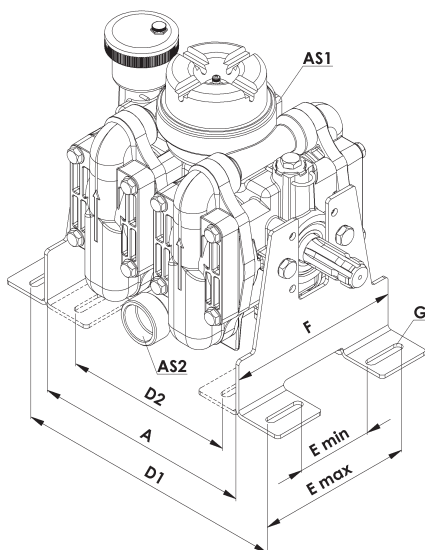

A	B	C
316	264	360
D1	D2	E _{Min}
396	246	110
E _{Max}	F	G
225	250	M12
Specified in mm		