



Electrical 5-way ball valve 2", 15 bar Ball bearing shaft

- individual adjustable seals
- high wear resistance
- ball bearing shaft
- integrated emergency operation
- optional: special connectors are available
- fittings for $\varnothing 60$ mm hoses
- optional: electric control with potentiometer
- Body made from liquid fertilizer proof anodised aluminium

Operating time pressure: max. 15 bar
 Flow rate: max. 700 l/min
 Inlet- \varnothing : 2"
 Outlet- \varnothing : 2"
 Ball valve: POM+PTFE
 Nominal voltage: 12 Volt
 Switch time: 360°/3,0 s
 Material: POM GF 25, PA, Aluminium, FPM and NBR seals

Options:

- Adapter for special connectors (e.g. with threads smaller than 2")

A	B	C	D	E	F	G
175	175	270	220	93	93	M10
Specified in mm						

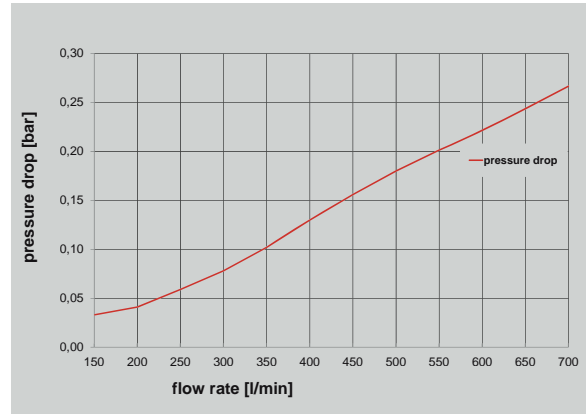
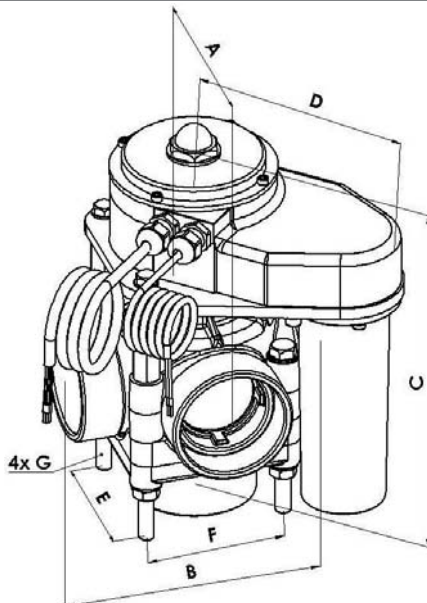

Article-No.	Type
82705	Electrical 5-way ball valve 2", 15 bar
Recommended fittings	
47713	Adapter for connector KH2/D1=47 cpl
47883	Adapter for connector KH2/D1=63 cpl
47737	Fitting G2/female cpl
47735	Fitting G2/male/L=47,5 cpl
47736	Fitting G2/male/L=75 cpl
82648	Nut G2 3/4 for 2" pressure valve
More Fittings: see section AS Fittings	

