



P70

- linear steady state characteristics
- integrated hydraulic accumulator
- safe to run dry (liquid)
- self-priming up to 4 meters depth
- liquid fertiliser-proof (AHL/UAN)

Capacity at 5 bar:	70 l/min
Nominal speed:	540 rpm
Operating time pressure:	max. 15 bar
Short-term pressure:	max. 20 bar
Speed range:	450-600 rpm
Spline shaft:	DIN 9611 / ISO 500
Standard working diaphragms:	2 x NBR
Accumulator diaphragms:	1 x NBR
Inlet- ϕ suction side:	AS40
Outlet- ϕ pressure side:	AS30
Lubrication:	Oil bath
Weight:	8,7 kg
Material:	Cast aluminium, partially anodised, NBR seals, POM, stainless steel: 1.4305

Options:

- **Desmopan® diaphragms**
- **Through shaft**
- **Hydraulic drive**

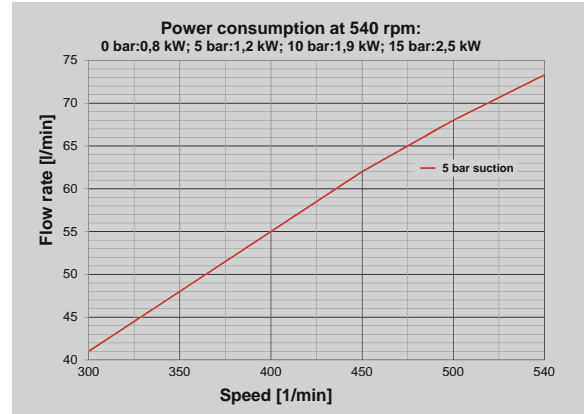

Pump options

Article-No.	Type
82372	Piston diaphragm pump P70 with bracket and pto protection
More variations on request	
Recommended fittings inlet (AS2)	
08275	Plug-in hose tail AS40/ ϕ 39/90° cpl
06247	Plug-in hose tail AS40/ ϕ 39 cpl
Recommended fittings outlet (AS1)	
08337	Plug-in hose tail AS30/ ϕ 25/90° cpl
33793	Plug-in hose tail AS30/ ϕ 33/90° cpl
81119	Plug-in hose tail AS30/ ϕ 25 cpl
01399	Plug-in hose tail AS30/ ϕ 33 cpl

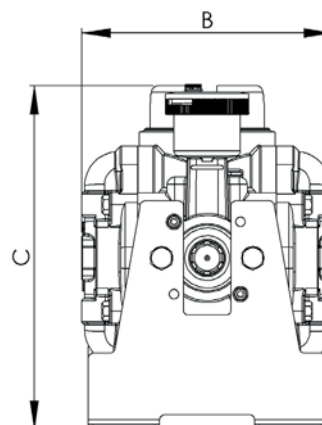
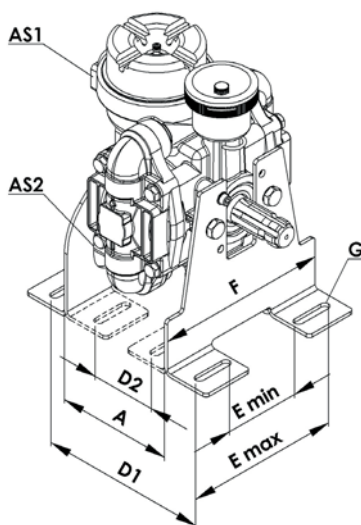

A	B	C
152	250	351
D1	D2	E _{Min}
282	132	110
E _{Max}	F	G
225	250	M12
specified in mm		